

ZG1163R CO₂ and Temperature Monitor Operating Instructions

Product Overview

Thank you for selecting ZG1163R desktop CO₂ monitor, ZG1163R CO₂ monitor is smart, compact and easy-to-use. In addition to measuring the CO₂ concentration, ZG1163R can also measure the ambient temperature and the relative humidity. This product is developed to detect the presence of CO₂ monitor in ambient air and help people to take care of Indoor Air Quality. ZG1163R can be widely used in the office building, school, exhibition, shopping mall, meeting room, fitness center, restaurant and other public place where personal comfort, healthy is important.

Features:

- ✓ The built-in Data logger can store 48 sets of CO₂ and temperature and RH in the past 24 hours; one log per 30 minutes.
- ✓ Max/Min mode can record the maximum and minimum concentration of CO₂ since the device has been last turned on.
- ✓ The Alarm mode the Alarm Level can be adjustable by user.
- ✓ The RCFS Mode can recover the original factory settings after the CO₂ device has been recalibrated, altered, or damaged.

1. Enter Button	4. Mode Button	7. Yellow LED Display (800-1200ppm)	10. Power inlet
2. Down Button	5. LCD display	8. Red LED Display (>1200ppm)	11. RJ45 socket (only for factory use)
3. Up Button	6. Green LED Display (<800ppm)	9. Gas Entry Hole	

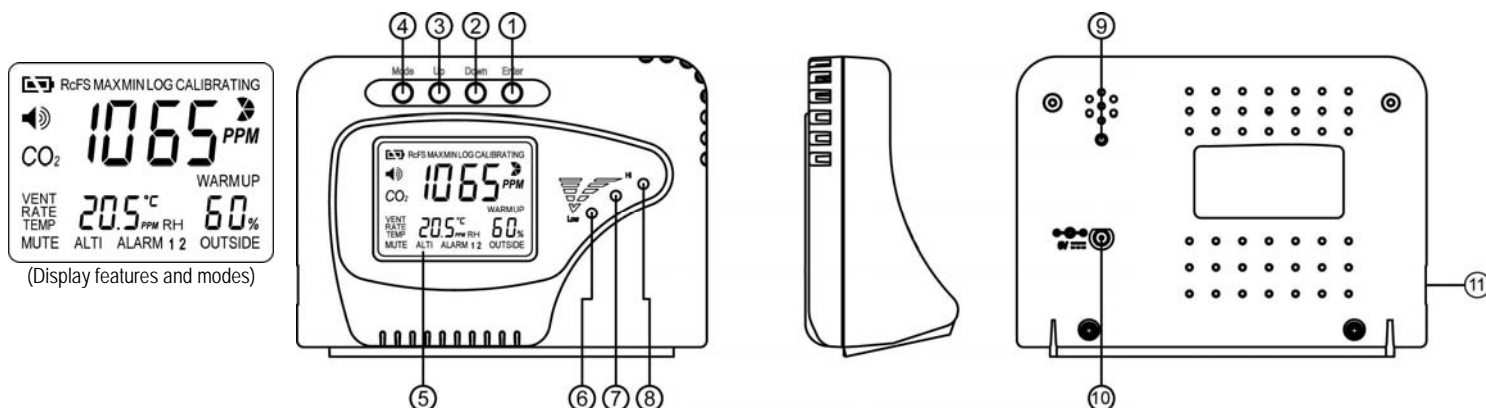

Mode Functions

There are several Modes which can be adjusted by user. These modes are Mute Mode, ALTI Mode, ALARM 1 Mode, ALARM 2 Mode, OUTSIDE Mode, CALI Mode, LOG Mode, MaxMin Mode and RcFS Mode in sequence.

MUTE	The beep alarm can be setting on/off under Mute Mode		ALTI	Compensate the pressure changes with appropriate altitude of location when measure	
ALARM 1	The first alarm level can be adjusted by user		ALARM 2	The second alarm level can be adjusted by user	
OUTSIDE	Modify the outside CO ₂ concentration for calculating the ventilation rate		CALI	Calibrate the sensor while the reading deviates from the actual CO ₂ concentration	
LOG	Show the past CO ₂ , Temperature and RH records in the past 24 hours		MaxMin	Show the Max and Min CO ₂ reading before being cleared or after Power On	
RcFS	Recover the factory setting to cancel customize setting				

Safety Instructions

Warning: Your safety is very important to us. To ensure to use the product correctly and safely, we would like to draw your attention to read the warning and entire User Manual before using the product. These are important safety information and should be observed at all times.

1. Please handle the devices lightly, do not subject the product to impact or shock.
2. Do not immerse the product in water. Water can cause electric shock, fire or malfunction which may result in damage.
3. Do not keep the product under the hot and moisture environment. Keep the product away from the heat source or near water.
4. Please use only the included power adaptor. Improper power adaptor or power sources can cause serious damage to the product, or result in injury or death to the user.

Caring for product

To ensure you receive the maximum benefit from using this product, please observe the follow guidelines.

1. Cleaning— Disconnect the power before clean. Use a damp cloth, do not use the liquid cleaning agent, such as benzene, thinner or aerosols.
2. Repair— Do not attempt to repair the product or modify the circuitry by yourself. Please contact with the local dealer or a qualified repairman if the product needs servicing.

3. Air circulation---The vents allow the air circulation liquid for measurement of the CO2 concentration and the ventilation should not be blocked.

Customize Settings

When the power has been connected, The ZG1163R CO2 monitor will begin to work. In order to meet your personal requirements, it is advisable to set up the customizing parameters.

WarmUp: It lasts approximately 1min before WARM UP disappears; all MODE functions will not response during warm up.

Temperature (°C/°F) RH and Ventilation Rate:

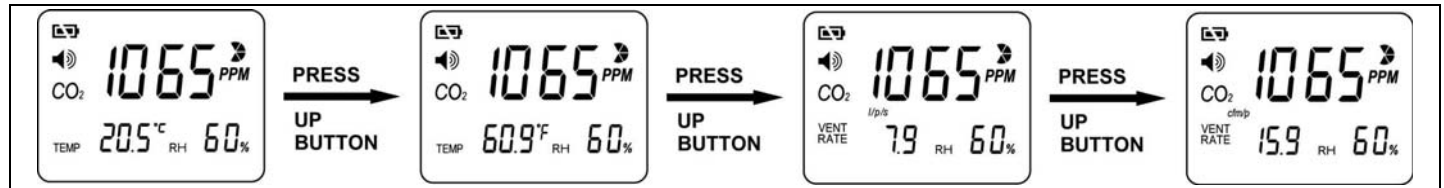

1. Press up/down to select the temperature, RH and ventilation rate modes.
2. When pressing up button, the LCD display sequence is Temp °C -> Temp °F -> Vent Rate lps -> Vent Rate cfm/p
When pressing down button, The LCD display sequence is reverse.

*Note: Temp °C refers to Temperature in Celsius; Temp °F refers to Temperature in Fahrenheit. Vent Rate lps refers to Liter Per Second Per Person; Vent Rate cfm/p refers to Cubic Feet Per Minute Per Person

Using the MUTE function:

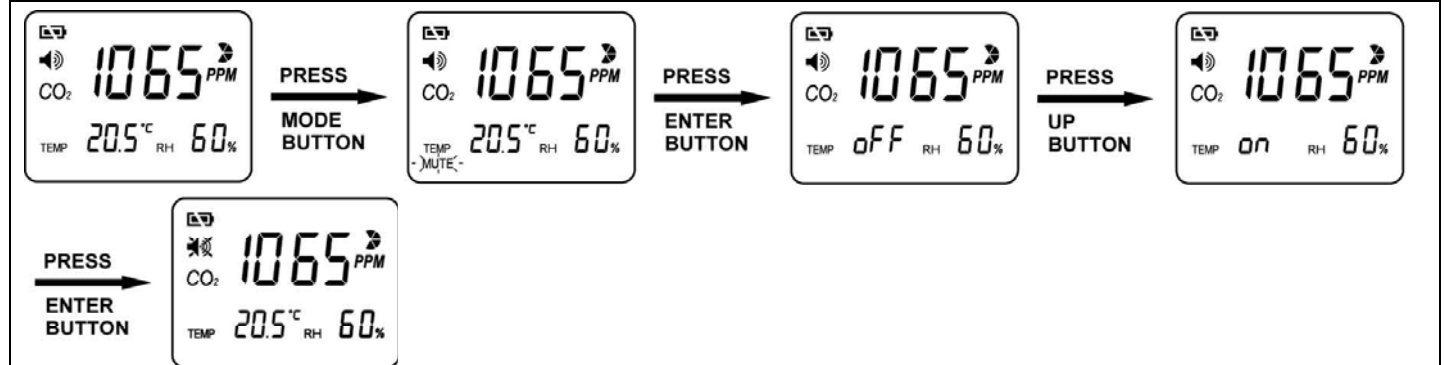

1. Press Mode, the speaker icon flashes simultaneously.
2. Press Enter, use up/down to select the on/off.
3. Press Enter again to save the data.

Note: The factory setting with alarm is buzzer off, user can set the alarm on/off under MUTE function.

Using the ALTI mode:

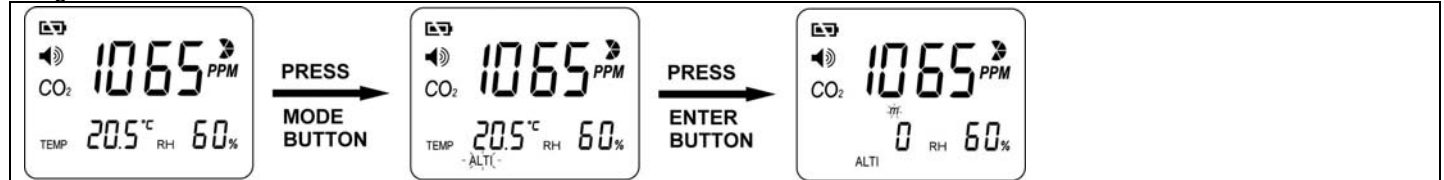

1. Press Mode, the ALTI icon flashes.
2. Press Enter, ALTI shows on the display, press the mode button to alter between the m(meter) and ft(feet).
3. Adjust altitude (step=100m/500ft) by up/down button.
4. Press Enter again to save the data.

Setting the ALARM 1 level:

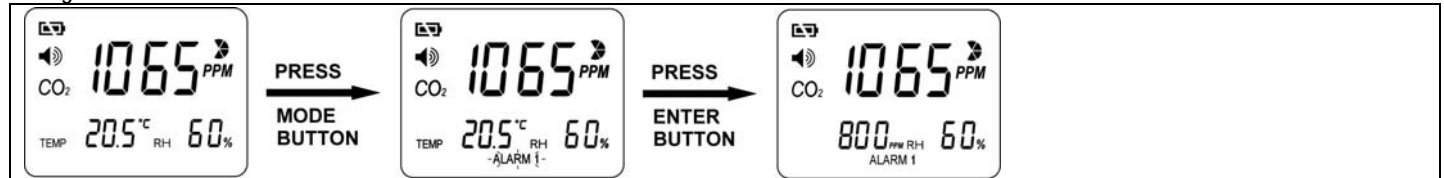

1. Press Mode, the ALARM 1 icon flashes.
2. Press Enter. Using the Up/Down to set the parameter, the default ALARM 1 is 800 ppm.
3. Press Enter again to save the data.

*Note:1) When CO2 Alarm level is $\geq 1,000$ ppm, the interval is ± 100 ppm, when the CO2 Alarm level is $< 1,000$ ppm, the interval is ± 50 ppm

2) After setting with new alarm level parameter, the green LED will light when CO2 concentration below the alarm 1 level.

Setting the ALARM 2 level:

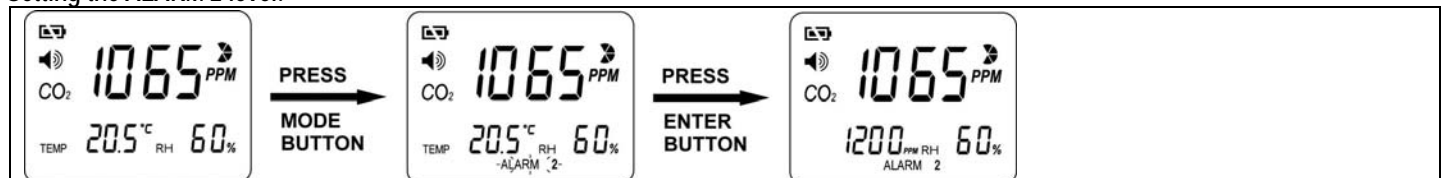

1. Press Mode, the ALARM 2 icon flashes.
2. Press Enter. Using the Up/Down to set the parameter, the default ALARM 2 is 1200 ppm.
3. Press Enter again to save the data.

*Note: 1) When CO2 Alarm level is $\geq 1,000$ ppm, the interval is ± 100 ppm, when the CO2 Alarm level is $< 1,000$ ppm, the interval is ± 50 ppm.

2) After setting with new alarm level parameter, the green LED will light when CO2 concentration below the alarm1 level. The red LED will light when CO2 concentration exceeds the alarm 2 level, the yellow LED will light when CO2 concentration is between the alarm1 level and the alarm 2 level.

Using the OUTSIDE mode:

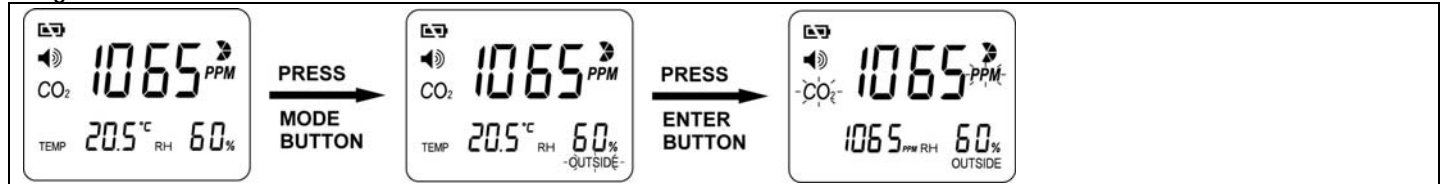

1. Press Mode, the OUTSIDE icon flashes.
2. Press Enter, shows OUTSIDE, CO2 and ppm flashes. Press the Up/Down to adjust the data.
3. Press Enter to save the setting. After the modification, the VENT Rate will change.

*Note: Ventilation rate represents how much air is introduced into the indoor space from outside. Low numbers indicate low ventilation rates and potentially poor air quality. High levels indicate excessive ventilation and potential excessive energy usage. To obtain an accurate measurement, reading should be taken 2-3 hours after occupancy has stabilized in a space or at a peak in daily CO2 concentrations. For indoor air quality control, CO2 value is an indicator of ventilation rate. 400ppm (Parts Per Million) is the default CO2 concentration outside according to ASHRAE: American Society of Heating, Refrigeration and Air conditioning Engineers.

Using the CALI (calibration) mode:

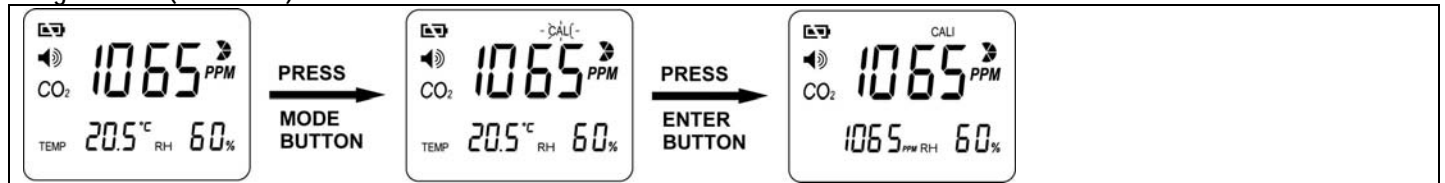

1. Press Mode, The CALI icon flashes.
2. Press Enter, the CALI icon on the display. Adjust the CO2 reading by Up/Down button.
3. Press Mode for more than 10sec, CALIBRATING flashes. Calibration will be done automatically after about 3 minute and the LCD will display "Pass" or "Fail." If it shows "Fail," please try again.

Using the LOG mode:

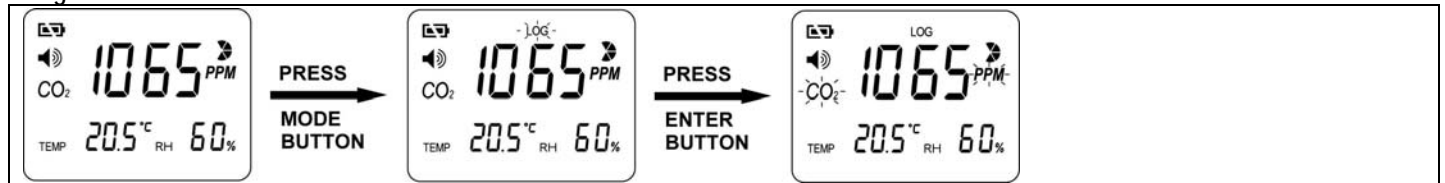

1. Press Mode, LOG icon flashes.
2. Press Enter, CO2 reading and Temperature show on the LCD.
3. Press Up/Down to page up/down the reading.

*Note: With the Built-in Datalogger, ZG1163R can provide the past CO2, temperature and RH reading within the past 24 hours. The log interval is 30 minutes per data. ZG1163R is connected with power and used for the first time. If the working time is more than 30 minutes, ZG1163R will have CO2, RH and temperature reading in datalogger, if the working time is less than 30 minutes, the LCD will display "NULL" while using the LOG function.

Using the MAX MIN mode:

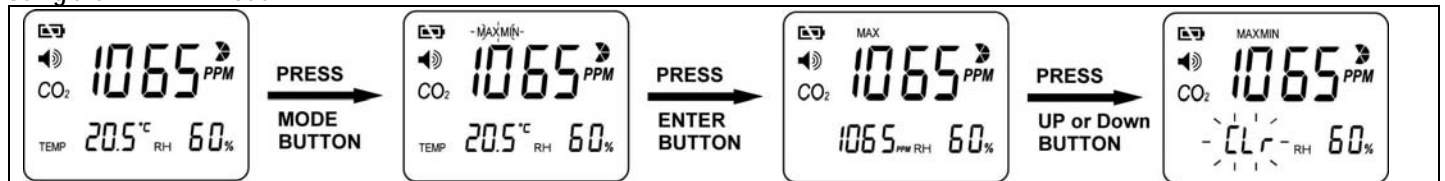

1. Press Mode, the MAX MIN icon flashes.
2. Press Enter, the MAX and MIN CO2 reading alternatively shows.
3. Press Down and the "CLr" will flash on the LCD. Press Enter to CLEAR the MAX and MIN record.

*Note: With the Built-in MAX MIN mode, ZG1163R can provide the Maximum and Minimum CO2 readings since the device has last been turned on. If users press up/down to clear the MAX and MIN CO2 reading record, ZG1163R will provide the new MAX and MIN CO2 reading from that time.

Using the "RcFS" Mode:

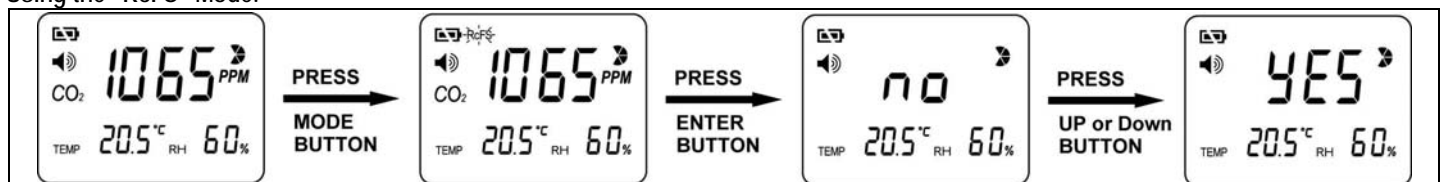

1. Press Mode, The RcFS icon flashes.
2. Press Enter, the icon "no" shows on the LCD, Press the Up/Down to select the no/yes.
3. After selecting, press Enter to save the setting.

*Note: If the user sets the data or calibrates the ZG1163R incorrectly, use the RcFS (recover the factory Setting) to come back the default factory setting.

SPECIFICATIONS

Method - NDIR

Display - LCD

Independent CO₂, RH and Temperature readings. Calculates and Displays Ventilation Rates

Sample Method - Diffusion or flow through (50 ~200 ml/min)

CO₂, Temperature & RH Specification:

CO ₂ Specification			
Measurement Range	0-3,000 ppm display		
Display Resolution	1ppm at 0~1,000ppm; 5ppm at 1,001~2,000ppm; 10ppm at 2,001~3,000ppm		
Accuracy	0~2,000ppm: ±70 ppm or ±5% of reading, whichever is greater; over 2000ppm: +/-7%		
Temperature Dependence	Typ. ±0.2% of reading per °C or ±2 ppm per °C, whichever is greater, referenced to 25°C		
Pressure Dependence	0.13% of reading per mm Hg (Corrected via user input for altitude)		
Repeatability	±20 ppm @ 400ppm	Response Time	About 2min for 63% of step change
Warm-Up Time	<60 seconds at 22°C	Zone LED Display	Green:<800ppm; Yellow:800~1200ppm;Red: >1200ppm
Temperature Specification			
Temperature Range	0°C to 50°C (32°F to 122°F) display	Display Resolution	0.1°C (0.1°F)
Display Options	°C/°F	Response Time	20-30 minutes (case must equalize with environment)
Accuracy	±1°C (±2°F) When the fan blows to the device directly, the accuracy of temperature is + / -1.5 degC		
RH Specification		Operating Conditions	
Measurement Range	20%-90% RH	Operating Temperature	0°C to 50°C (32°F to 122°F)
Display Resolution	1%RH	Humidity Range	0 ~ 95% RH non-condensing
Accuracy:	±5%RH@23°C	Storage Conditions	
Response time:	<5 min for 63% of step change	Storage Temperature	-20°C to 60°C(-4°F to 140°F)
Power Supply			
Power Supply	100 ~ 240 VAC 50 / 60 Hz 6 VDC from external AC/DC adapter which is included in package (Use specified AC adapter only)		

Dimension

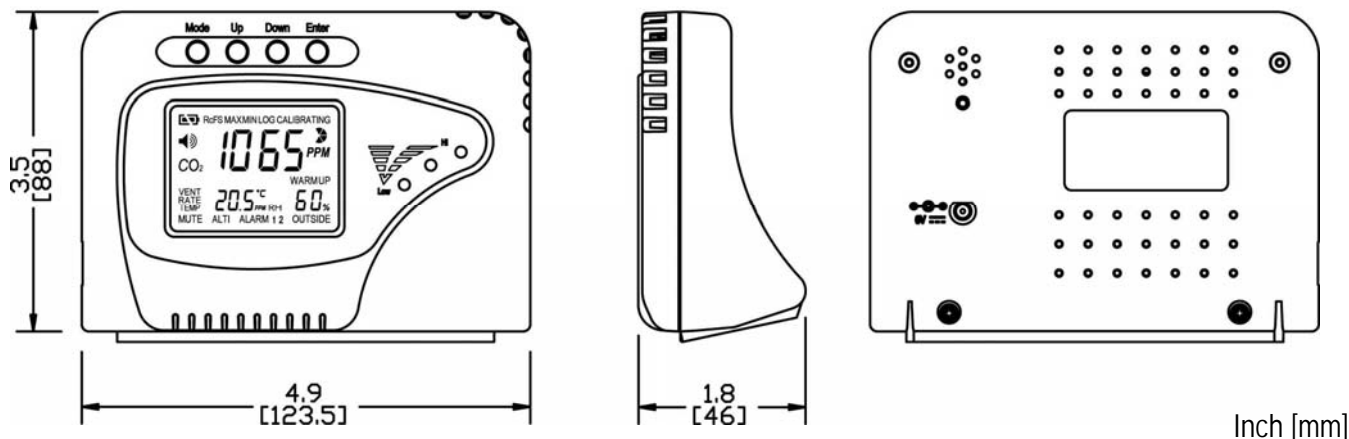

Fault Codes & Troubleshooting Guide

This section includes a list of Frequently Asked Questions for problems you may encounter with the ZG1163R CO₂ Monitor.

Fault Icon	Description of the fault	Suggested Actions
「Err 3」	The ambient temperature has exceeded the operating temperature range 0°C to 50°C (32°F to 122°F)	This error will clear when the temperature returns to the range between 0°C to 50°C (32°F to 122°F).
「Err 5」 「Err 6」	EEPROM System Problem	Please reconnect AC adapter to ZG1163R CO ₂ Monitor. If the "Err5, Err6" still appears, please contact the Service Department for further assistance.