

# ZG1683R 3 IN 1 CO<sub>2</sub> Monitor (CO<sub>2</sub>+Temp.+RH) Operating Instructions

## Product Overview

Thank you for selecting ZG1683R desktop CO<sub>2</sub> monitor, ZG1683R CO<sub>2</sub> monitor is smart, compact and easy-to-use. In addition to measuring the CO<sub>2</sub> concentration, ZG1683R can also measure the ambient temperature and the relative humidity (CO<sub>2</sub>+Temp.+RH). This product is developed to detect the presence of CO<sub>2</sub> in ambient air and help people to take care of Indoor Air Quality. ZG1683R can be widely used in the office building, school, exhibition hall, shopping mall, meeting room, fitness center, restaurant and other public places where personal comfort, healthy is important.

### Features:

- ☑ Three different LED display shows the current Indoor Air Quality
- ☑ Press MUTE button for alarm on/off.
- ☑ Built in the LCD Backlight for easy reading in the dark.

### Warnings:

- ☑ Please take off the AC power adapter and store it well when this CO<sub>2</sub> monitor left idle for long.
- ☑ This CO<sub>2</sub> monitor is for home use, not suitable for certifying the test results.
- ☑ If use this CO<sub>2</sub> monitor for testing, ZG1683R does not guarantee the test results.

1. Green LED Display (<800ppm)
2. Yellow LED Display (800~1200ppm)
3. Red LED Display (>1200ppm)
4. Mute Button
5. Power Inlet (Mini USB Socket)
6. Housing Stand
7. Screw Position
8. Ventilation Slots

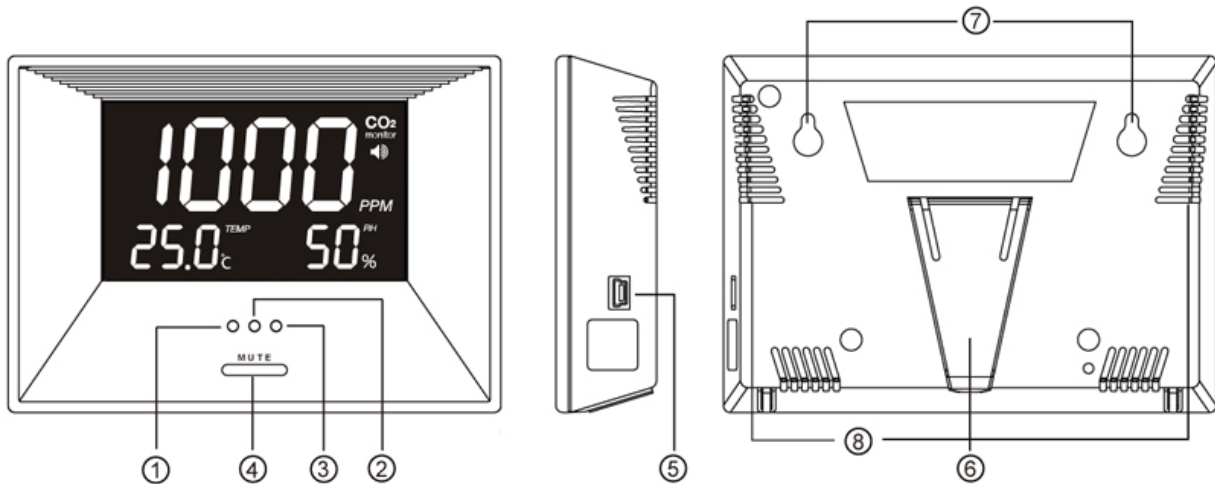

### EMC/RFI

Readings may be affected if the unit is operated within radio frequency electromagnetic field strength of approximately 3 volts per meter, but the performance of the instrument will not be permanently affected.

**Note:** Under the electromagnetic field of 3V/m, the reading will not meet the specification.

**Warm-Up Time: 2 MIN.**

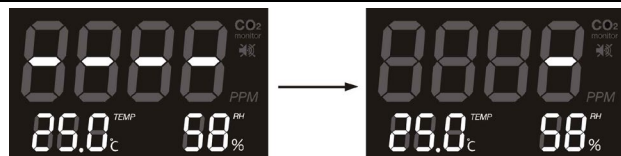

1. 2 min. warm-up time when first time power.
2. The LCD shows 4 bars with 1sec blank cycle during warm-up.
3. The MUTE button is disabled during warm-up.
4. The device shows the CO<sub>2</sub> reading after warm-up.

### Using the MUTE function:

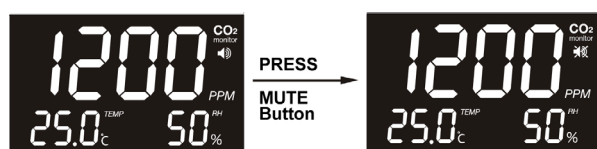

Press MUTE button to select buzzer on/off. If the "MUTE" function is off, while CO<sub>2</sub> concentration exceed the alarm level (>1200 ppm), there will be a buzzer.

**Note:** The device setting with alarm is buzzer on when power on first time, user can set the alarm on/off under MUTE function.

## Safety Instructions

**Warning:** Your safety is very important to us. To ensure to use the product correctly and safely, we would like to draw your attention to read the warning and entire User Manual before using the product. These are important safety information and should be observed at all times.

1. Please handle the devices lightly, do not subject the product to impact or shock. Otherwise, this may cause the accuracy drift.
2. Do not immerse the product in water. Water can cause electric shock, fire or malfunction which may result in damage.
3. Do not keep the product under the hot and moisture environment. Keep the product away from the heat source or near water.
4. Please use only the included power adaptor. Improper power adaptor or power sources can cause serious damage to the product, or result in injury or death to the user.

## Caring for product

To ensure you receive the maximum benefit from using this product, please observe the follow guidelines.

1. Cleaning— Disconnect the power before clean. Use a damp cloth, do not use the liquid cleaning agent, such as benzene, thinner or aerosols.
2. Repair— Do not attempt to repair the product or modify the circuitry by yourself. Please contact with the local dealer or a qualified repairman if the product needs servicing.
3. Air diffusion— The ventilation slots on the housing are designed for CO<sub>2</sub> diffusion, so these ventilation slots should not be blocked.

## Specifications

**Method** -Dual Beam NDIR (Non-Dispersive-Infrared)

**Display** - LCD Independent CO<sub>2</sub>, RH and Temperature readings

**Sample Method** - Diffusion or flow through (50~200 ml/min).

**CO<sub>2</sub> & Temperature Specification:**

<b>CO<sub>2</sub> Specification:</b>	
Measurement Range	0-3,000ppm
Display Resolution	1ppm at 0~1,000ppm; 5ppm at 1,001~2,000ppm; 10ppm at 2,001~3,000ppm
Accuracy	Under 25°C: ±80ppm or ±5% of reading (≤2000ppm); ±7% reading (>2000ppm)
Repeatability	±20 ppm @ 400ppm
Temperature Dependence	Typ. ±0.2% of reading per °C or ±2 ppm per °C, whichever is greater, referenced to 25°C
Response Time	About 2min for 63% of step change
Warm-Up Time	2 min. at 22°C
Zone LED Display	Green: <800ppm; Yellow: 800~1200ppm; Red: >1200ppm
<b>Temperature Specification:</b>	
Temperature Range	0°C~50°C (32°F~122°F)
Display Resolution	0.1°C (0.1°F)
Display Options	°C/°F
Accuracy	±1°C(±2°F) When the fan blows to the device directly, the accuracy of temperature is ±1.5°C
Response Time	20-30 minutes (case must equalize with environment)
<b>RH Specification:</b>	
Measurement Range	20%~90% RH
Display Resolution	1% RH
Accuracy	±5% RH @ 23°C
Response Time	<5 min for 63% of step change
<b>Operating Conditions:</b>	
Operating Temperature	0°C~50°C (32°F~122°F)
Humidity Range	0 ~95% RH non-condensing
<b>Storage Conditions:</b>	
Storage Temperature	-20°C~60°C (-4°F~140°F)
<b>Power Supply:</b>	
Power Supply	USB or 5 VDC from external AC/DC adapter which is included in package (Use specified AC adapter only)
DC Output Voltage	5VDC
AC Input Voltage & Frequency	100~240VAC, 0.2A 50/60Hz

## Installation Instruction

1. You can put ZG1683R on the table (please pull out the Housing Stand ⑥) or hang it on the wall.
2. Please note the following when hanging it on the wall.  
Choose a suitable location to install ZG1683R, fix the screws to the wall.  
Please see 「Dimension」 section to check the distance between the screws.

## Dimension

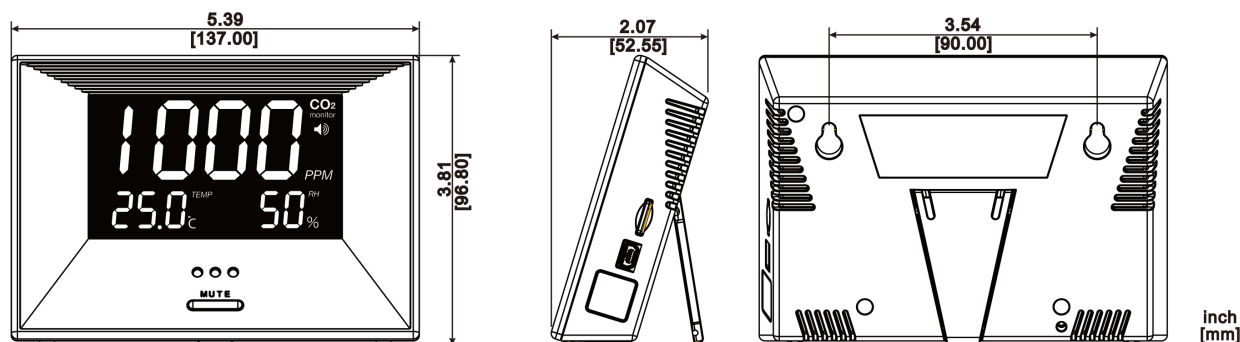

## Fault Codes & Troubleshooting Guide

This section includes a list of Frequently Asked Questions for problems you may encounter with the ZG1683R CO<sub>2</sub> Monitor.

Fault Icon	Description of the fault	Suggested Actions
「Err3」	The ambient temperature has exceeded the operating temperature range 0°C~50°C (32°F~122°F)	This error will clear when the temperature returns to the range between 0°C~50°C (32°F~122°F).
「Err5」 「Err6」	EEPROM System Problem	Please reconnect AC adapter to ZG1683R CO <sub>2</sub> Monitor. If the "Err5, Err6" still appears, please contact the Service Department for further assistance.